

# Pneumatic knife gate valve

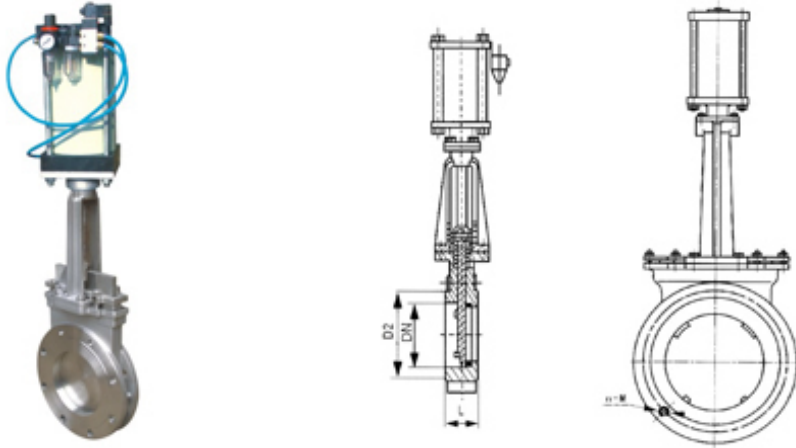

## Nominal diameters and coupling sizes

Nominal pressure MPa	Nominal diameter DN	L ength h	Flange diameter Bolt	Centr al round diameter	Coupled protruding part diameter	H	N-M	No min al pressure MP a	Nominal diameter DN	L ength	Flan ge dia met er Bolt	Centra diam
0.6	50	50	140	110	90	490	4-M12	1.0	350	90	500	4
	65	50	160	130	110	520	4-M12		400	100	565	5
	80	50	185	150	125	580	4-M16		450	120	615	5
	100	50	205	170	145	660	4-M16		500	130	670	6
	125	50	235	200	175	770	8-M16		600	130	780	7
	150	70	260	225	200	880	8-M16		700	160	895	8
	200	70	315	280	255	990	8-M16		800	160	1010	9
	250	70	370	335	310	1130	12-M16		900	160	1110	10

	300	80	435	395	362	1300	12-M20	1.6	1000	160	1220	11
	350	90	485	445	412	1450	12-M20		1200	200	1450	13
	400	100	535	495	462	1680	16-M20		50	50	160	13
	450	120	590	550	518	1850	16-M20		65	50	180	14
	500	130	640	600	568	2055	16-M20		80	50	195	14
	600	130	755	705	670	2400	20-M22		100	50	215	15
	700	160	860	810	775	2760	24-M22		125	50	245	20
	800	160	975	920	880	3155	24-M27		150	70	280	24
	900	160	1075	1020	980	3555	24-M27		200	70	335	29
	1000	160	1175	1120	1080	3900	28-M27		250	70	405	33
	1200	200	1400	1340	1295	4400	32-M30		300	80	460	40
	1.0	50	50	160	125	100	490		4-M16	350	90	520
65		50	180	145	120	520	4-M16	400	100	580	53	
80		50	195	160	135	580	4-M16	450	120	640	59	
100		50	215	180	155	660	8-M16	500	130	705	66	
125		50	245	210	185	770	8-M16	600	130	840	77	
150		70	280	240	210	880	8-M20	700	160	910	88	
200		70	335	295	265	990	8-M20	800	160	1020	99	
250		70	390	350	320	1130	12-M20	900	160	1120	110	
300		80	440	400	368	1300	12-M20	1000	160	1255	121	
								1200	200	1485	132	