

# Pressure seal forged steel gate valve

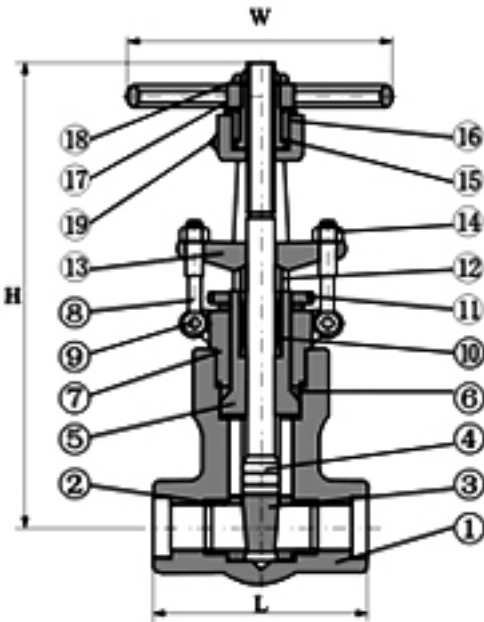

Material list							
Item	Part name	CS to	AS to	SS to ASTM			
		ASTM	ASTM	F304(L)	F316(L)		
		A105	F22	F304(L)	F316(L)		
1	Body	A105	A182 F22	A182 F304(L)	A182 F316(L)		
2	Seat	A276 420	A276 304	A276 04(L)	A276 316(L)		

3	Wedge	A182 F430&410	A182 F304	A182 F304(L)	A182 F316(L)		
4	Stem	A182 F6	A182 F304	A182 F304(L)	A182 F316(L)		
5	Pressure seat	A105	A182 F304	A182 F304(L)	F316(L)		
6	Pressuring	A182 F304L			A276 316L		
7	Bonnet	A105	A182 F22	A182 F304(L)	A182 F316(L)		
8	Gland eyebolt	A193 B7	A193 B16	A193 B8(M)			
9	Pin	A276 F420		A182 F304(L)			
10	Packing	Flexible Graphite		PTFE			
11	P. S. Lock nut	A194 2H	A194 4	A194 8	A194 8M		
12	Gland	A276F 420		A182 F304			
13	Gland flange	A216 WCB		A182 F304			
14	Nut	A194 2H	A194 4	A194 8	A194 8M		
15	Yoke Nut	A276 410					
16	Retaining nut	A194 2H	A194 4	A194 8	A194 8M		
17	Handwheel	A197					
18	Lock nut	A194 H	A194 4	A194 8	A194 8M		
19	Oil cup	Brass					
Suitable medium		W. O. G etc	W. O. G etc	Nitric acid, Acetic acid etc			

Note: Other material are available upon request.

CS=Carbon steel; AS=Alloy steel; SS=Stainless steel;

**Size (MM) & Weight (KG)**

NPS		1/2"	3/4"	1"	1 1/4"	1 1/2"	2"
L	900Lb-150Lb	140	140	140	178	178	216
	2500Lb	186	186	186	232	232	279
H(Open)		321	321	321	380	414	502
W		160	160	180	200	250	280
Weight	900LB-1500LB	11.5	10.8	10.5	19.6	21	55.4
	2500LB	12.3	11.6	10.8	26	28.4	60