

# Taiyi valve

<http://www.taiyivalve.com>

## forged steel gate valve with extended nipple

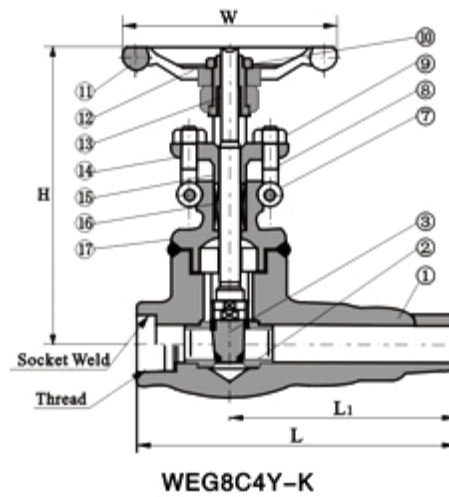
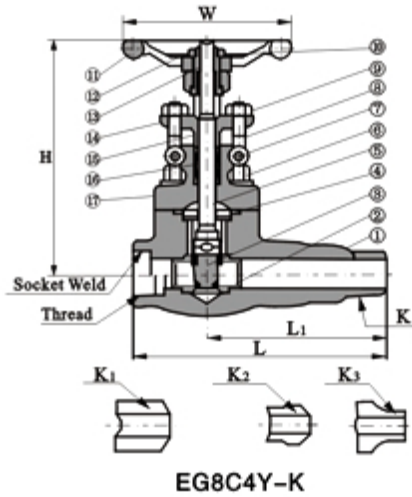

forged steel gate valve with extended nipple

### Material List

Item	Part name	CS to ASTM	AS to ASTM	SS to ASTM	
		A105	F22	F304(L)	F316(L)
1	Body	A105	A182 F22	A182 F304(L)	A182 F316(L)
2	Seat	A276 420	A276 304	A276 304(L)	A276 316(L)
3	Wege	A182 410&F430	A182 F304	A182 F304(L)	A182 F316(L)

4	Gasket	SS+Flexible graphite		316+PTFE	
5	Stem	A182 F6	A276 F304	A182 F304(L)	A182 F316(L)
6	Bolt	A193 B7	A193 B16	A193 B8	A193 B8M
7	Pin	A276 420		A276 304	
8	Bolt	A193 B7	A193 B16	A193 B8	A193 B8M
9	Nut	A194 2H	A194 4	A194 8	A194 8M
10	Lock nut	A194 2H	A194 4	A194 8	A194 8M
11	Handwheel	A197			
12	Nameplate	SS			
13	Yoke nut	A276 420			
14	Gland flange	A105	A182 F11	A182 F316(L)	
15	Gland	A276 410		A182 F304(L)	A182 F316(L)
16	Packing	Flexible Graphite		PTFE	
17	Bonnet	A105	A182 F22	A182 F304(L)	A182 F316(L)
Suitable medium		W.O.G etc.	W.O.G etc.	Nitric acid,Acetic acid etc.	
Suitable temperature		-29°C~425°C	-29°C~550°C	-29°C~200°C	

Note:Other material are available upon request.

CS=Carbon steel;AS=Alloy steel;SS=Stainless steel;

**Size(MM)&Weight(KG)**

NPS	Red.bore	3/8"	1/2"	3/4"	1"
	Full bore		3/8"	1/2"	3/4"
L1		10.75	10.75	10.75	120
L		147	147	153.5	175.5
H(Open)		158	158	169	197
W		100	100	100	125
Weight	Bolted	3.1	2.9	3.4	5.5
	Welded	2.8	2.6	3.1	5.1